

CGS Ball Bearing Slide Series

120 lb. Full Extension Ball Bearing Slide



Specifications

Length: 10"-28"(250mm-700mm)

Height: 45.3 mm (1.79")

Side Space: 12.7 mm \pm 0.2 (1/2")

Travel: Full Extension

Mount: Sidemount

Load: 54 kg (120 lb.) Pair (Max)

Disconnect: Lever Disconnect

Finish: Zinc Plated

Material: Cold Rolled Steel

Packaging: 10 Pair/Carton

Features

- Heavy Gauge Steel Construction
- Front Levered Disconnect
- 32mm Hole Pattern
- Ball Bearing Carriage Hold Out Feature
- 1 /2" Side Clearance
- 120 Lb. Dynamic Weight Capacity ANSI
- BIFMA Tested & Certified
- WI Tested+ Certified
- Steel Rear Mounting Brackets

Applications

- Kitchen & Bath Cabinets
- Store Fixtures
- Architectural Millwork
- Office Furniture
- Medical Equipment Carts & Storage Racks
- Carts & Storage Racks
- Manufactured Housing

Full Extension Slide

Full Extension Ball Bearing Slides



Cabinet Members

Drawer Members

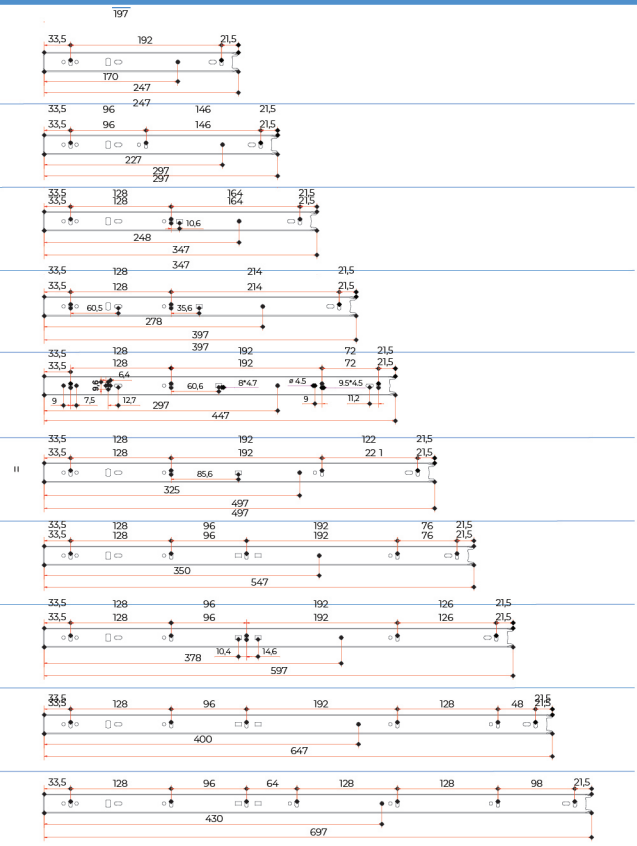
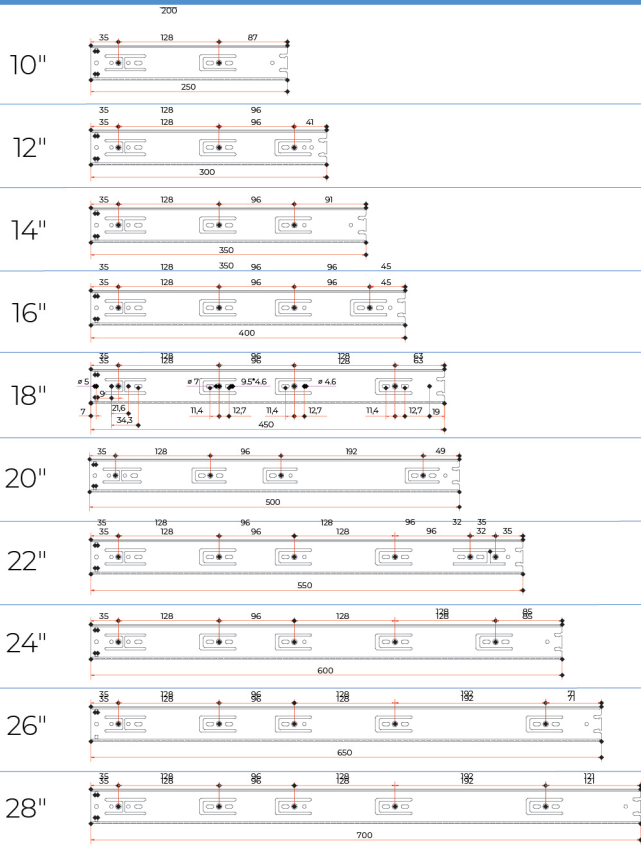

Ordering

Cabinet

Item	Description	Carton Quantity
280-1010-32	250 mm (10") 120 lb.	10
280-1011-32	300 mm (12") 120 lb.	10
280-1012-32	350 mm (14") 120 lb.	10
280-1013-32	400 mm (16") 120 lb.	10
280-1014-32	450 mm (18") 120 lb.	10
280-1015-32	500 mm (20") 120 lb.	10
280-1016-32	550 mm (22") 120 lb.	10
280-1017-32	600 mm (24") 120 lb.	10
280-1018-32	650 mm (26") 120 lb.	10
280-1019-32	700 mm (28") 120 lb.	10

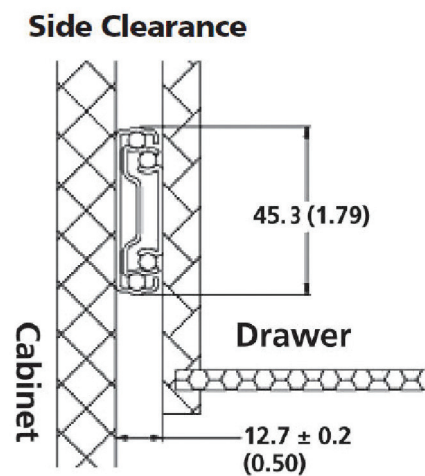

5775 McLaughlin Rd, Mississauga, Ontario L5R 3P7
 TF: 1.866.200.0564 | T: 905.625.0564
 inquiries@comtradsourcing.com | www.comtradsourcing.com